



## Commercial Gas Ultra High Efficiency Water Heater



### Features:



Bradford White is ISO registered to the 9001-standard.

- Thermal Efficiency up to 99.1%
- Three Pass Flue System
- Low NOx Premix Power Burner
- Ultra Quiet Operation
- Submerged Combustion Chamber
- Non-CFC foam insulation
- Flexible Venting — Conventional, Through-the-Wall or Direct Vent
- 1" NPT side connection for hydronic applications
- Electronic Controls
- Zero Inch Clearance to combustibles
- Vitraglas® lined tank
- Four protective magnesium anode rods
- Hand hole cleanout — Allows inspection of tank interior
- Factory installed Hydrojet® Sediment Reduction System
- Factory installed dielectric fittings
- 60 gallon (227 Liters) tank capacity in 125,000 (36.6 kW), 150,000 (43.9 kW) and 199,999 (58.6 kW) BTU/hr Inputs
- 100 Gallon (379 Liters) tank capacity in 150,000 199,999, 250,000 and 300,000 BTU/hr Inputs
- 3" Optional Concentric Vent Kit
- ASME Construction available
- NSF Construction available with optional kit
- Brass drain valve
- T&P relief valve factory installed
- Three year limited warranty on steel tank
- One year limited warranty on parts

MANUFACTURED UNDER ONE OR MORE OF THE FOLLOWING U.S. PATENTS:  
5,954,492; 5,761,379; 5,943,984; 5,081,696; 5,988,117; 6,142,216; 5,199,385;  
6,684,821; 5,574,822; 5,372,185; 5,485,879; 5,277,171; (B1)5,341,770; 5,660,165;  
5,596,952; 5,682,666; 4,904,428; 5,023,031; 5,000,893; 4,669,448; 4,829,983;  
4,808,356; 5,115,767; 5,092,519; 5,052,346; 4,416,222; 4,628,184; 4,861,968;  
4,672,919; Re. 34,534. OTHER U.S. AND FOREIGN PATENT APPLICATIONS  
PENDING. CURRENT CANADIAN PATENTS: 1,272,914; 1,280,043; 1,289,832;  
2,045,862; 2,112,515; 2,108,186; 2,107,012, 2,092,105.



Photo is of EF-100T-199

## Standard Equipment Features:

**Thermal Efficiency up to 99.1%** — Fully condensing design

**Three Pass Flue System** — The three pass flue system keeps the hot combustion gases moving at a high velocity. The combination of high turbulence and velocity causes an enormous rate of heat transfer into the water.

**Low NOx Premix Power Burner** — Developed for the eF Series®, a turbulent flame shoots down the submerged combustion chamber. This turbulence causes a thorough mixing of the gas and air for optimum combustion and high heat transfer efficiencies. — Far exceeds California emission requirements.

**Submerged Combustion Chamber** — Submerging the combustion chamber in the center of the water storage tank minimizes radiant heat loss and improves efficiency.

**Non-CFC foam insulation** — Surrounds the tank surface, saving energy by retarding loss of heat.

**Electronic Controls** — Adjustable electronic thermostat 80°-180°F recycling Energy Cut Off (E.C.O.) shuts off all gas in event of an overheat condition.

**Zero Inch Clearance** — The eF Series® jacket is cool to the touch and is approved for zero inches to combustibles for unsurpassed installation flexibility.

**Vitraglas® lined tank** — Bradford White's water heater tanks are protected from the corrosive effects of hot water by an exclusive ceramic porcelain-like coating. Our high silica Vitraglas® lining provides a tough interior surface for Bradford White's water heater tanks.

**Four protective magnesium anode rods** — Employed to provide an extra measure of corrosion protection for longer life.

**Factory installed Hydrojet® Sediment Reduction System** — Cold inlet sediment reduction device made of stainless steel for increased durability. Helps prevent sediment build up in tank.

**Factory installed dielectric fittings** — All heaters equipped with special water heater nipples for longer heater life. No special dielectric fittings to buy.

**Flexible Venting** — The eF Series® can vent vertically or horizontally with either 3" or 4" PVC, CPVC or ABS vent pipe, and is approved for direct vent closed combustion applications, or those applications that require inside air for combustion. Foam Core pipe is permitted on the entire venting system. The eF Series® is also approved for unbalanced venting, which means the air intake pipe doesn't have to be vented the same distance as the exhaust.

<u>Model Numbers</u>	<u>Max 3" PVC, ABS &amp; CPVC</u>	<u>Max 4" PVC, ABS &amp; CPVC</u>
EF-60T-125	120 ft.	170 ft.
EF-60T-150	100 ft.	150 ft.
EF-60T-199	80 ft.	130 ft.
EF-100T-150	120 ft.	170 ft.
EF-100T-199	100 ft.	150 ft.
EF-100T-250	80 ft.	130 ft.
EF-100T-300	60 ft.	110 ft.

### Determining required vent length

1. Determine the total length of straight vent pipe (in feet) required for both the intake and the exhaust.
2. Add 5 feet of venting for every 90° elbow.
3. Add 2½ feet of venting for every 45° elbow.
4. **Total vent length cannot exceed "Max Length" in the above venting table.**
5. **Air intake cannot exceed exhaust by more than 30 feet in any venting situation.**

**NOTICE: Do not include the 3" exhaust elbow or vent terminals in determining maximum vent length.**

**Three year limited warranty on steel tank** — Heavy gauge steel automatically formed, rolled and welded to assure a continuous seam for glass lining.

**One year limited warranty on parts**

# Dimensions

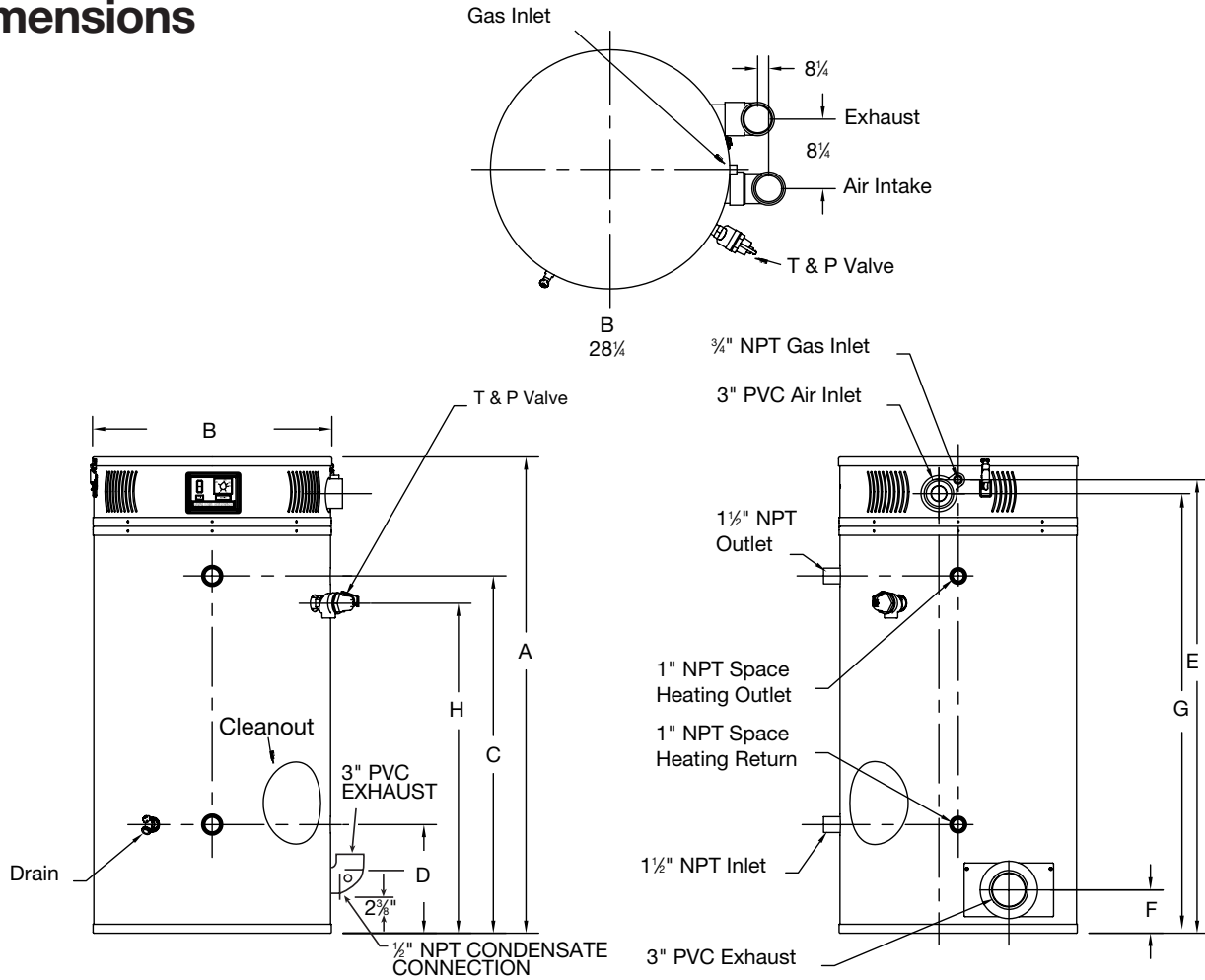

NOTE: Diagrams are for both the 60 and 100 gallon models.

# Commercial Ultra High Efficiency

**eF Series® MODELS** Includes installed T&P Valve and Electronic Ignition.

V	●	★	MODEL NUMBER	INPUT BTU	1ST HR. DEL. GAL. AT 100°F RISE	RECOVERY GPH AT DEGREE RISE			STG. CAP U.S. GAL.	THERM EFF. %	DIMENSIONS IN INCHES								SHPG. WT. (LBS.)			
						40°F	100°F	140°F			A HT.	B DIA.	C HOT OUT	D COLD IN	E FL. TO GAS CONN.	F FL. TO VENT OUTLET	G FL. TO AIR INTAKE	H FL. TO T&P VALVE CONN.		WTR. CONN. DIA.	GAS CONN. DIA.	RELIEF VALVE OPEN
V	●	★	EF-60T-125E-3N(A)	125,000	187	364	145	104	60	96.0	57	28 1/4	42	12 1/2	53 3/4	5 1/2	52 1/2	39 1/2	1 1/2	3/4	3/4	570
V	●	★	EF-60T-150E-3N(A)	150,000	211	423	169	121	60	93.0	57	28 1/4	42	12 1/2	53 3/4	5 1/2	52 1/2	39 1/2	1 1/2	3/4	3/4	570
V	●	★	EF-60T-199E-3N(A)	199,999	265	558	223	159	60	92.0	57	28 1/4	42	12 1/2	53 3/4	5 1/2	52 1/2	39 1/2	1 1/2	3/4	3/4	570
V	●	★	EF-100T-150E-3N(A)	150,000	250	450	180	129	100	99.1	78	28 1/4	63	12 1/2	74 1/4	5 1/2	73 3/4	60 1/2	1 1/2	3/4	3/4	900
V	●	★	EF-100T-199E-3N(A)	199,999	309	597	239	171	100	98.5	78	28 1/4	63	12 1/2	74 1/4	5 1/2	73 3/4	60 1/2	1 1/2	3/4	3/4	900
V	●	★	EF-100T-250E-3N(A)	250,000	364	735	294	210	100	97.0	78	28 1/4	63	12 1/2	74 1/4	5 1/2	73 3/4	60 1/2	1 1/2	3/4	1	900
V	●	★	EF-100T-300E-3N(A)	300,000	405	836	335	239	100	92.0	78	28 1/4	63	12 1/2	74 1/4	5 1/2	73 3/4	60 1/2	1 1/2	3/4	1	900

V	●	★	MODEL NUMBER	INPUT KW	1ST HR. DEL. LPH. AT 56°C RISE	RECOVERY LPH AT DEGREE RISE			STG. CAP LITER	THERM EFF. %	DIMENSIONS IN MILLIMETERS								SHPG. WT. (KG)			
						22°C	56°C	78°C			A HT.	B DIA.	C HOT OUT	D COLD IN	E GAS CONN.	F FL. TO VENT OUTLET	G FL. TO AIR INTAKE	H FL. TO T&P VALVE CONN.		WTR. CONN. DIA.	GAS CONN. DIA.	RELIEF VALVE OPEN
V	●	★	EF-60T-125E-3N(A)	36.6	708	1378	545	394	227	96.0	1448	718	1067	327	1365	130	1324	994	38	19	19	259
V	●	★	EF-60T-150E-3N(A)	43.9	799	1601	640	458	227	93.0	1448	718	1067	327	1365	130	1324	994	38	19	19	259
V	●	★	EF-60T-199E-3N(A)	58.6	1003	3112	844	602	227	92.0	1448	718	1067	327	1365	130	1324	994	38	19	19	259
V	●	★	EF-100T-150E-3N(A)	43.9	946	1703	681	488	379	99.1	1981	718	1600	327	1899	130	1857	1527	38	19	19	408
V	●	★	EF-100T-199E-3N(A)	58.6	1170	2260	905	647	379	98.5	1981	718	1600	327	1899	130	1857	1527	38	19	19	408
V	●	★	EF-100T-250E-3N(A)	73.2	1378	2782	1113	795	379	97.0	1981	718	1600	327	1899	130	1857	1527	38	19	25	408
V	●	★	EF-100T-300E-3N(A)	87.9	1533	3165	1268	905	379	92.0	1981	718	1600	327	1899	130	1857	1527	38	19	25	408

For propane gas models change suffix "N" to "X" and remove "E" from the model number. Example: EF-100T-150-3X

V - 115V A.C. Required

● - Electronic Ignition

★ - Listed with California Energy Commission

(A) ASME - All models are available with ASME construction. To order ASME construction add the (A) to the end of the model number. Example: EF-60T-125E-3NA

Note: The weight is the same for both ASME and Non-ASME models.

NSF Construction Available with optional kit

Complies with SCAQMD low NOx requirements — 10.39 nanograms per joule

Design certified by CSA International (formerly AGA/CGA)

Amp Draw range = 1.0 to 1.8 amps

150 PSI Working Pressure (1034 kPa), 300 PSI Test Pressure (2068 kPa)

# Specifications

All models are design certified by CSA International (formerly AGA/CGA) for up to 180°F. (82°C) application as an Automatic Storage Heater, and an Automatic Circulating Tank Heater.

As an Automatic Storage Heater, all models are complete self-contained water heating systems. It needs no separate storage tank, pump, wiring or elaborate piping network. When equipped with a mixing valve, it will supply 180°F (82°C). sanitizing and 140°F (60°C) general purpose hot water simultaneously. These models can be used either as a single unit or in multiples connected in parallel.

## Sample Specification

The water heater shall be a Bradford White model EF-\_\_\_\_ with a rated storage capacity of not less than \_\_\_\_ gallons/ liters, a minimum gas input of \_\_\_\_\_ BTU/hr, a minimum recovery of \_\_\_\_ GPH/LPH at 100°F (56°C) temperature rise, and a Thermal Efficiency Rating of \_\_\_\_%. It shall be design certified by CSA International (formerly AGA and CGA) for 180°F (82°C) application, either with or without a separate storage tank. The tank shall be lined with Vitraglas® vitreous enamel and shall have a bolted hand hole cleanout. The tank shall have four extruded magnesium anode rods installed in separate head couplings. This water heater shall be equipped with stainless steel cold water inlet, Hydrojet® Sediment Reduction System. The heater shall be insulated with Non-CFC foam. This water heater shall be equipped with an electronic ignition system, an ASME rated T&P relief valve and a premix closed combustion system for direct venting using either 3" (76mm) or 4" (102mm) PVC, CPVC or ABS vent pipe. (115V AC required). The water heater shall be factory assembled and tested. The water heater shall be approved for zero clearance to combustibles. The control shall be an adjustable electronic thermostat to any temperature up to 180°F (82°C). A recycling Energy Cut Off (E.C.O.) shuts off all gas in the event of an overheat condition. The entire installation shall be made in compliance with state and local codes and ordinances.

*Dimensions and specifications subject to change without notice in accordance with our policy of continuous product improvement.*



For U.S. and Canada field service,  
contact your professional installer or  
local Bradford White sales representative.

**Sales/800-523-2931**  
**Fax/215-641-1670**

**Technical Support/800-334-3393**  
**Fax/269-795-1089**

**Warranty/800-531-2111**  
**Fax/269-795-1089**

**International:**  
**Telephone/215-641-9400**  
**Telefax/215-641-9750**

**Fax on Demand:**  
**888-538-7833**

**www.bradfordwhite.com**



**Sales/Technical Support**  
**866-690-0961**  
**905-238-0100**

**Fax/905-238-0105**

**www.bradfordwhitecanada.com**

**Count On Bradford White**  
**For *Everything* Hot Water**