

# The Conserver™ Dual Flush HET



# The Conserver™ Dual Flush HET

1.6 gpf/6.0 lpf & 1.0 gpf/4.2 lpf  
Dual-Flush, Two-Piece Toilet

4207/4208



## FEATURES

- High-efficiency toilet (HET)
- Choose either 1.6 or 1.0 gpf\*
- Wide 2" glazed trapway
- Top-mounted push button flush release
- Stain-resistant vitreous china
- 18" x 10" footprint, Model 4207
- 20-1/2" x 10" footprint, Model 4208
- Limited lifetime warranty

\* Estimated average consumption of 1.28 gpf

## AVAILABLE COLORS



WHITE (130)

## SPECIFICATIONS

- Model 4207: 12" rough-in round toilet, 69 lb, consists of bowl (Model 4370) and tank (Model 4484)
- Model 4208: 12" rough-in elongated toilet, 72 lb, consists of bowl (Model 4375) and tank (Model 4484)
- Model 7484: Tank lid for Model 4484, 10 lb

## INSTALLATION

- Installation instructions supplied

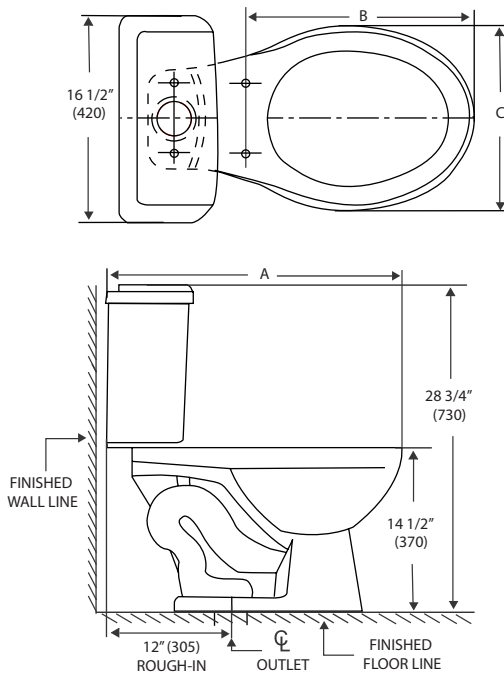

Dimensions may vary (+) or (-) 1/4". Dimensions shown in parentheses are in millimeters: 25.4 mm = 1 inch. Note: Fixture dimensions are nominal and conform with dimension and performance requirements of ASME/ANSI Standards A112.19.2M. PSI rating: 20 minimum to 80 maximum per ASME A112.19.2. Dimensions subject to change or cancellation without notice. Briggs is not responsible for the use of superseded or voided specification information.

	4207	4208
<b>A</b>	26 3/8" (670)	28 3/8" (720)
<b>B</b>	16 1/2" (420)	18 1/2" (470)
<b>C</b>	14 1/8" (360)	14 3/8" (365)



Design | Technology | Innovation

**(800) 888-4458**  
www.briggsindustries.com