

Combi1™

Residential Atmospheric Vent Combi1™ Energy Saver Gas Water Heater System



Photo is of
C-SW2-75T10BN

FEATURING:



The Combi1™ Models Feature:

- **Bradford White ICON System™**—Intelligent gas control with proven millivolt powered technology and built-in piezo igniter. A standard, off the shelf thermopile converts heat energy from the pilot flame into electrical energy to operate the gas valve and microprocessor. No need for external electricity.
 - **Enhanced Performance**—Propriety algorithms provide enhanced First Hour Delivery ratings and tighter temperature differentials.
 - **Advanced Temperature Control System**—Microprocessor constantly monitors and controls burner operation to maintain consistent and accurate water temperature levels.
 - **Intelligent Diagnostics**—An exclusive green LED light prompts the installer during start-up and provides ten different diagnostic codes to assist in troubleshooting.
 - **Pilot On Indication**—Flashing green LED provides positive indication that pilot is on.
 - **Separate Immersed Thermowell**—High strength advanced polymer composite thermowell provides isolation between electric temperature sensor and surrounding water. No need to drain the tank when removing gas valve.
- **Heat Exchanger**—Single Wall 1½" O.D. glass coated (Vitraglas®) carbon steel coil.
- **Low Heat Exchanger Head Loss**—Up to 10 GPM flow, with less than 5 ft. of head loss. Greatly reduces the required pump size for heat exchange.
- **Factory Installed Hydrojet 2™ Total Performance System**—Cold water inlet sediment reducing device helps prevent sediment build up in tank. Increases first hour delivery of hot water while minimizing temperature build up in tank.
- **1" NPT Front Supply and Return Connections.**
- **Vitraglas® Lining**—Bradford White tanks are lined with a exclusively engineered enamel formula that provides superior protection from the highly corrosive effects of hot water. This formula (Vitraglas®) is fused to the steel surface by firing at a temperature of over 1600°F.
- **Optimizer™ Temperature Control System**—Integrated thermostatically controlled mixing device ensures a comfortable outlet temperature while providing a steady flow of hot water (required).
- **2" Non-CFC Foam Insulation**—Covers the sides and top of tank, reducing the amount of heat loss. This results in less energy consumption, improved operation efficiencies and jacket rigidity.
- **Pedestal Base.**
- **Water Connections**—¾" NPT factory installed true dielectric fittings.
- **Two Protective Aluminum Anode Rods.**
- **T&P Relief Valve**—Installed.
- **Brass Drain Valve**—Tamper proof.



10-Year Limited Tank and Heat Exchanger Warranties / 6-Year Limited Warranty on Component Parts.

For more information on warranty, please visit www.bradfordwhite.com

For products installed in USA, Canada and Puerto Rico. Some states do not allow limitations on warranties. See complete copy of the warranty included with the heater.

Residential Atmospheric Vent Gas Water Heater System

Combi1™ Energy Saver Models

NATURAL GAS AND LIQUID PROPANE GAS

Meet or exceed ASHRAE 90.1b (current standard) C.E.C. Listed
80% Recovery Efficiency

Model Number	Capacity		LP BTU/Hr Input	Recovery 90°F Rise*				A Floor to Flue Conn. in.	B Jacket Dia. in.	C Vent Size in.	D Floor to T&P Conn. in.	E Floor to Gas Conn. in.	F Floor to Exchanger Inlet in.	G Floor to Exchanger Outlet in.	H Floor to Top of Heater in.	J Floor to Water Conn. in.	K Depth in.	Approx. Shipping Weight lbs.	
	U.S. Gal.	Imp. Gal.		Nat. BTU/Hr Input	Nat. U.S. GPH	Nat. Imp. GPH	LP U.S. GPH												LP Imp. GPH
C-SW2-75T10BN	72	61	76,000	76,000	81	70	81	70	62½	26	4	51½	13½	29½	51½	59	60½	30½	292

Model Number	Capacity		LP kW Input	Recovery 50°C Rise*		A Floor to Flue Conn. mm.	B Jacket Dia. mm.	C Vent Size mm.	D Floor to T&P Conn. mm.	E Floor to Gas Conn. mm.	F Floor to Exchanger Inlet mm.	G Floor to Exchanger Outlet mm.	H Floor to Top of Heater mm.	J Floor to Water Conn. mm.	K Depth mm.	Approx. Shipping Weight kg.
	Liters	Nat. kW Input		Nat. Liters/Hour	LP Liters/Hour											
C-SW2-75T10BN	272	22.3	22.3	317	317	1575	660	102	1321	356	737	1321	1499	1549	754	128

Propane model features a Titanium Stainless Steel propane burner. For propane (LP) models change suffix "BN" to "SX".
*Based on manufacturers rated recovery efficiency.
CAEF is .55 and CAAFE% is 80.0.

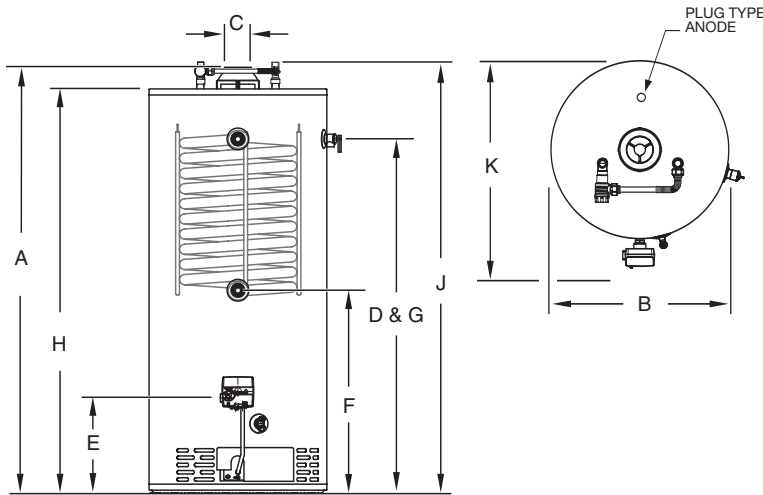

Heat Exchanger Head Loss	
GPM	Ft. of Hd. Loss
2	trace
5	0.4
8	2.3
10	4.6
12	6.9

Heat Exchanger Values*

Supply Temperature	140°F	120°F	100°F
Return Temperature	120°F	100°F	80°F
Differential	20°F	20°F	20°F
Flow Rate	4.1 GPM	5.6 GPM	5.6 GPM
Net Output	35,500 BTU/Hr.	47,500 BTU/Hr.	47,500 BTU/Hr.

*These values were obtained using 180°F stored tank temperature.

Net Output is the space heating capacity based on normal piping and pickup allowance of 15%.

Actual values may vary based on circulator flow rate, number of zones, water and space heating demands. Numbers subject to change.

Meets NAECA Requirements

General

All gas water heaters are certified at 300 PSI test pressure (2068 kPa) and 150 PSI working pressure (1034 kPa). All potable water connections are 3/4" NPT (19mm) on 11" (203mm) centers. All heat exchanger connections are 1" NPT (25mm). All gas connections 1/2" (13mm).

All models design certified by CSA International (formerly AGA/CGA), ANSI Z-21.10.3 and peak performance rated.

Dimensions and specifications subject to change without notice in accordance with our policy of continuous product improvement.

Suitable for Water (Potable) Heating and Space Heating.

Toxic chemicals, such as those used for boiler treatment, shall NEVER be introduced into the potable water side. The potable side of this unit may NEVER be connected to any existing heating system or component(s) previously used with a non-potable water heating appliance. The heat exchanger side of the unit may be used in space heating applications.



Ambler, PA

For U.S. and Canada field service, contact your professional installer or local Bradford White sales representative.

Sales 800-523-2931 • Fax 215-641-1670 / Technical Support 800-334-3393 • Fax 269-795-1089 • Warranty 800-531-2111 • Fax 269-795-1089

International: Telephone 215-641-9400 • Telefax 215-641-9750 / www.bradfordwhite.com



BRADFORD WHITE-CANADA™ INC. Sales / Technical Support 866-690-0961 / 905-238-0100 • Fax 905-238-0105 / www.bradfordwhite.com

Built to be the Best™

©2009, Bradford White Corporation. All rights reserved.