

Light Duty Commercial High Input Direct Vent Energy Saver Gas Water Heater



Photo is of
DH-65T-55FB-3N

FEATURING:



The Direct Vent FVIR Defender Safety System[®] Models Feature:

- **Bradford White ICON System[™]**—Intelligent gas control with proven millivolt powered technology and built-in piezo igniter. A standard, off the shelf thermopile converts heat energy from the pilot flame into electrical energy to operate the gas valve and microprocessor. No need for external electricity.
 - **Enhanced Performance**—Propriety algorithms provide enhanced First Hour Delivery ratings and tighter temperature differentials.
 - **Advanced Temperature Control System**—Microprocessor constantly monitors and controls burner operation to maintain consistent and accurate water temperature levels.
 - **Intelligent Diagnostics**—An exclusive green LED light prompts the installer during start-up and provides ten different diagnostic codes to assist in troubleshooting.
 - **Pilot On Indication**—Flashing green LED provides positive indication that pilot is on.
 - **Separate Immersed Thermowell**—High strength advanced polymer composite thermowell provides isolation between electric temperature sensor and surrounding water. No need to drain the tank when removing gas valve.
- **Closed Combustion**—All air for combustion is taken directly from the outside. The co-axial vent pipe (pipe inside a pipe) draws combustion air in through the outer pipe (6"), and exhausts the products of combustion through the inner pipe (4"). The co-axial vent pipe at the top of the unit can be rotated for venting flexibility.
- **Reinforced Seals**—Seals surround the closed combustion chamber and the FVIR inner door, preventing the ignition of flammable vapors outside of the water heater.
- **Maintenance Free**—The vent piping and the closed combustion chamber with reinforced seals do not require regular cleaning under normal operating conditions.
- **Sight Window**—Offers a view into the combustion chamber to observe the operation of the pilot and burner.
- **Factory Installed Hydrojet[®] Total Performance System**—Cold water inlet sediment reducing device helps prevent sediment build up in tank. Increases first hour delivery of hot water while minimizing temperature build up in tank.
- **Vitraglas[®] Lining**—Bradford White tanks are lined with a exclusively engineered enamel formula that provides superior protection from the highly corrosive effects of hot water. This formula (Vitraglas[®]) is fused to the steel surface by firing at a temperature of over 1600°F.
- **Cast Aluminum Air Intake Boot**—A cast molded air intake boot provides exceptional installation durability.
- **Telescoping Solid Vent Kits**—Multiple kits (see reverse side) allow up to 8ft. vertical and 8ft. horizontal vent lengths (horizontal termination only).
- **Flexible Vent Kit**—The maximum vent length (horizontal and vertical) can be flexed to 100" (horizontal termination only).
- **Side Connections**—3/4" NPT tapings allow easy connections for space heating applications (Potable water only).
- **1" Non-CFC Foam Insulation**—Surrounds the tank surface, saving energy by reducing the amount of heat loss.
- **Temperature Control Up To 180°F**—Not recommended for 180°F sanitizing.
- **Pedestal Base.**
- **Water Connections**—3/4" NPT factory installed true dielectric fittings.
- **Factory Installed Heat Traps.**
- **Protective Magnesium Anode Rod.**
- **T&P Relief Valve**—Installed.
- **Brass Drain Valve**—Tamper proof design.

3 or 5 Year Limited Tank Warranty / 1-Year Limited Warranty on Component Parts.

For more information on warranty, please visit www.bradfordwhite.com

For products installed in USA, Canada and Puerto Rico. Some states do not allow limitations on warranties. See complete copy of the warranty included with the heater.

Commercial Direct Vent Gas Water Heater

Light Duty High Input Energy Saver Models

NATURAL GAS AND LIQUID PROPANE GAS

Meet or exceed ASHRAE 90.1b (current standard) C.E.C. Listed
78% Recovery Efficiency

Model Number	Capacity		Recovery at 100°F Rise*				A Floor to Center Line of Vent in.	B Jacket Dia. in.	C Vent Size in.	D Floor to T&P Conn. in.	E Floor to Gas Conn. in.	F Floor to Top of Heater in.	G Floor to Space Heating Outlet in.	H Floor to Water Conn. in.	J Floor to Space Heating Inlet in.	K Depth in.	Approx. Shipping Weight lbs.		
	U.S. Imp. Gal.	Imp. Gal.	Nat. BTU/Hr. Input	LP BTU/Hr. Input	Nat. U.S. Imp. GPH	Nat. U.S. Imp. GPH												LP U.S. Imp. GPH	
DH-50T-50FB-3N	48	40	50,000	48,000	47	39	45	38	75 ¹ / ₄	20	4-6	52 ¹ / ₄	15	58 ³ / ₄	52 ¹ / ₄	59 ³ / ₄	15 ³ / ₄	31 ¹ / ₄	190
DH-65T-55FB-3N	65	54	55,000	55,000	51	43	51	43	78 ¹ / ₄	22	4-6	56	15	62	56	63	15 ³ / ₄	34 ¹ / ₄	226
DH-75T-60FB-3N	75	62	60,000	57,000	56	47	53	44	75 ¹ / ₂	24	4-6	52	15	59	52	60	16 ¹ / ₂	35 ¹ / ₄	261

Model Number	Capacity		Recovery at 56°C Rise*				A Floor to Center Line of Vent mm.	B Jacket Dia. mm.	C Vent Size mm.	D Floor to T&P Conn. mm.	E Floor to Gas Conn. mm.	F Floor to Top of Heater mm.	G Floor to Space Heating Outlet mm.	H Floor to Water Conn. mm.	J Floor to Space Heating Inlet mm.	K Depth mm.	Approx. Shipping Weight kg.
	Liters	Liters	Nat. kW Input	LP kW Input	Nat. Liters/Hour	LP Liters/Hour											
DH-50T-50FB-3N	182	142	14.7	14.1	178	170	1411	508	102-152	1327	381	1492	1327	1518	400	787	86
DH-65T-55FB-3N	246	205	16.1	16.1	193	193	1988	559	102-152	1422	381	1575	1422	1600	400	864	102
DH-75T-60FB-3N	284	232	17.6	16.7	212	200	1918	610	102-152	1321	381	1499	1320	1524	419	889	118

All Propane models feature a Titanium Stainless Steel propane burner. For Propane (LP) models change suffix "B" to "S" and "N" to "X".

For 5 year models change suffix from "3" to "5".

*Based on manufacturers rated recovery efficiency.

Telescoping Solid Vent Kit (239-47811-00) or Flexible Vent Kit (239-47813-00) can be ordered and shipped with water heater, or ordered and shipped separately

For vent kit components and venting instructions, refer to Installation and Operating Manual.

Optional Telescoping Solid Vent Kits:

- Kit "F" Telescopes from 4³/₈" to 5¹/₈" Part No. 243-42516-00
- Kit "G" Telescopes from 6¹/₈" to 9¹/₈" Part No. 243-42517-00
- Kit "H" Telescopes from 13³/₈" to 23¹/₈" Part No. 243-42514-00
- Kit "I" Telescopes from 49¹/₈" to 95¹/₈" Part No. 243-42512-00

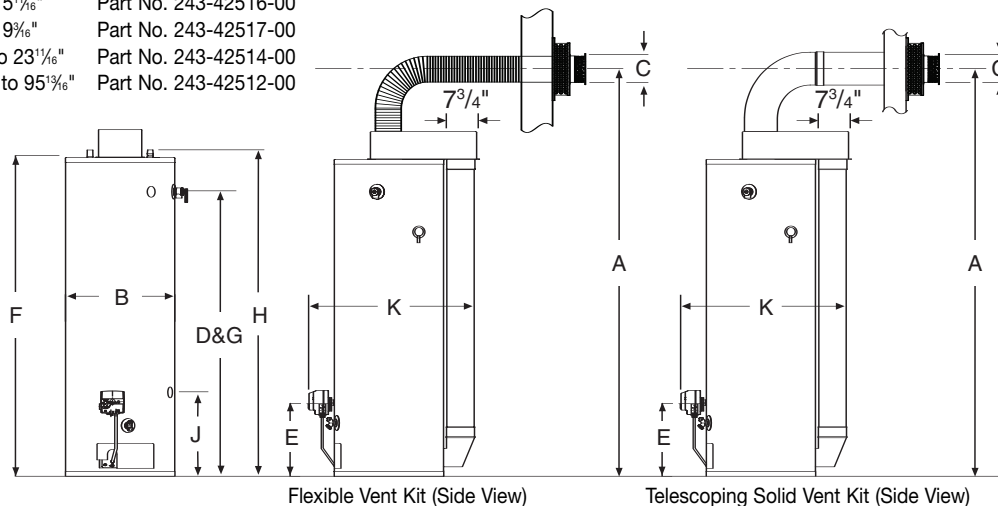

Meets NAECA Requirements

General

All gas water heaters are certified at 300 PSI test pressure (2068 kPa) and 150 PSI working pressure (1034 kPa). All potable water connections are 3/4" NPT (19mm) on 11" (203mm) centers. All gas connections 1/2" (13mm).

All models design certified by CSA International (formerly AGA/CGA), ANSI Z-21.10.1 and peak performance rated.

Dimensions and specifications subject to change without notice in accordance with our policy of continuous product improvement.

Suitable for Water (Potable) Heating and Space Heating.

Toxic chemicals, such as those used for boiler treatment, shall NEVER be introduced into this system. This unit may NEVER be connected to any existing heating system or component(s) previously used with a non-potable water heating appliance.



For U.S. and Canada field service, contact your professional installer or local Bradford White sales representative.

Sales 800-523-2931 • Fax 215-641-1670 / Technical Support 800-334-3393 • Fax 269-795-1089 • Warranty 800-531-2111 • Fax 269-795-1089

International: Telephone 215-641-9400 • Telefax 215-641-9750 / www.bradfordwhite.com

BRADFORD WHITE-CANADA INC. Sales / Technical Support 866-690-0961 / 905-238-0100 • Fax 905-238-0105 / www.bradfordwhite.com

Built to be the Best™

©2009, Bradford White Corporation. All rights reserved.